

Perfect for commercial/residential work; compact footprint; 4 sections roll-n-fold with a 3rd section that can articulate up to 240°, 5 inch line, 170 cubic meters per hour.



PUMP SPECIFICATIONS

Maximum output (fully variable)	157 yd ³ /hr (120 m ³ /hr)
Concrete cylinder (hard chromed)	9" x 70" (230 mm x 1800 mm)
Strokes per minute	28
Concrete pressure (rod side)	1043 PSI (72 Bar)
Concrete pressure (head side)	1600 PSI (114 Bar)
Hopper capacity	21 ft ³ (600 liters)
S-Tube	9" x 7" (230 mm x 180 mm)
Hydraulic pump	Rexroth A11VL0190
Cycling system	All hydraulic sensing w/ manual overrides
Max. aggregate size	2 1/2" (65 mm)

BOOM SPECIFICATIONS

4 section roll & fold (vert. reach)	104'33" (31.8 m)
Maximum horizontal reach	91'86" (28 m)
Reach from front of truck	83' (25.5 m)
Unfolding height	24' 3" (7.4 m)
Rotation	370 degree
Section articulation	92 / 180 / 250 / 245
Proportional Boom	Yes
Delivery line	5" (125 mm)
1st Section	26'3" (8m)
2nd Section	22'11" (7 m)
3rd Section	22'11" (7 m)
4th Section	19'18" (6 m)

OUTRIGGER SPECIFICATIONS

All hydraulic	Yes
Front spread	232" (5.9 m)
Rear spread	237" (6.03 m)
Max Outrigger weight	13,800 Kg (30,423 Lbs)

STANDARD ACCESSORIES

Heat pipe and elbows	One safety sling
Wireless proportional remote control HBC	Tool box with basic repair items and testing gage
One wire remote control	Spare hydraulic hose kit
Boom light kit	Spare sensing valves
Working lamps on the side panels	Spare pumping relay and fuses
Magnetic working lamp	Two clamps (125 mm)
Blow-out system cap (water)	Outrigger pads 4 pieces
Hopper vibrator	Grundfos water pump
Automatic greasing system (hopper only)	One Water hose plus nozzle
End hose length 4m (13')	Two clean up sponges
	Clean-up scraper
	Two manual books

WORKING DIAGRAM

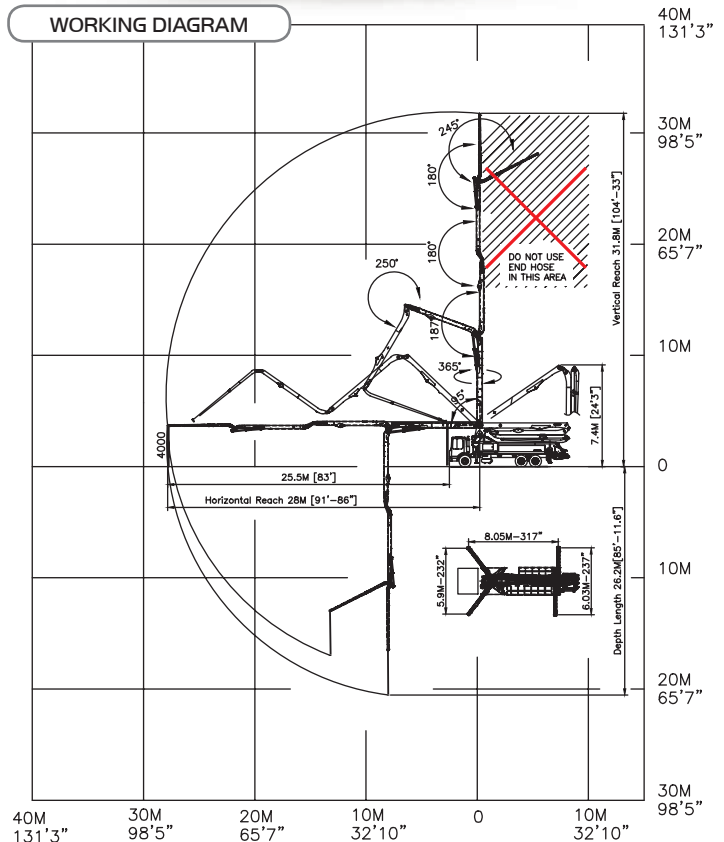

WEIGHT DIAGRAM

